

DOI 10.36074/logos-19.12.2025.016

STUDY OF METHODS FOR IMPROVING COMMUNICATION QUALITY IN OPTICAL TRANSMISSION SYSTEMS

Arif H. Hasanov¹

1. Deputy Rector

Military Defense University, REPUBLIC OF AZERBAIJAN

ORCID ID: 0000-0002-8814-1590

Abstract: The topology ring structure optical fiber communication lines formed by optical user's terminals on the basis spectral and dense spectral multiplexing with frequency by division channels communication is investigated. The aim of the work is to study and analyze methods for constructing fiber-optic communication lines based on optical subscriber terminals (ST) of an optoelectronic communication channel based on the ring structure topology and determine the performance indicators of the functioning of optical signal transmission systems. Some characteristics efficiency of the functioning systems transfer optical signals are defined.

INTRODUCTION

Construction of broadband digital networks NGN (Next Generation Network) based on optical WDM and DWDM (Wavelength Division Multiplexing & Dense WDM) technologies that provide a transport service for transmitting and integrating information of any nature in a common network environment [1, 2].

In the reference model of the architecture of broadband digital networks NGN, its three lower functional levels form the logical structure of the transport system or the actual network of the optical communication system.

The development of new types of telecommunication services represented in the broadband network NGN (Integrated Services Digital Network) and the growing volumes of transmitted information of mixed type require the creation of fiber-optic communication lines (FOCL) based on optical subscriber terminals (ST) of the optoelectronic communication channel (CC) with increased by efficiency [3, 4].

Studies have shown [5, 6, 7, 8] that the current state of modern optical networks based on technical means of an optoelectronic CS does not fully meet



SEZIONE 8.

SCIENZE MILITARI, SICUREZZA NAZIONALE E SICUREZZA DEL CONFINE DI STATO

the requirements of the ITU recommendation – T (International Telecommunication Union for Telecommunications) to ensure the effective functioning of optical signal transmission systems.

These shortcomings narrow the boundaries of their widespread use in multi-service low and high-speed optical ring optical ring local networks (LAN).

GENERAL FORMULATION OF THE PROBLEM

Taking into account the above and on the basis of the study [9,10], it was established that the formalization of the fiber-optic communication lines (FOCL) performance quality task based on optical ST optoelectronic CC can be represented as a set of performance indicators of each of the subsystems, i.e.

$$E_{ef} = W \{ \max[V_b, E_{ie}, E_{ep}], \min[S_s, P_{BER}, C_a] \}, \quad (1)$$

where V_b – ST bit rate at optoelectronic CC; E_{ep} - the energy potential of fiber optic fibers based on optical ST; S_s – optical receiver sensitivity ST [11, 12];

E_{ie} – information efficiency of optical signal transmission systems;

P_{BER} – the average probability of bit error (BER) receiving optical signals;

C_a – cost of hardware and software of fiber-optic networks in a ring topology [13, 14].

In this paper, we study the creation FOCL based on optical ST optoelectronic CC on the topology of the ring structure and determine the performance indicators of the optical signal transmission systems.

IMPLEMENTATION OF THE FOCL STRUCTURE WITH A DOUBLE RING STRUCTURE

It is known [15, 16, 17, 18] that ring topologies are very popular when creating highways modern telecommunication optical communication networks. This is primarily due to economic considerations and the satisfaction structural reliability requirements.

To create a rational structure FOCL, consisting optical ST, it is necessary to create an effective FOCL configuration with a ring topology that provides an improvement in the efficiency of optical communication networks [5, 9, 12].

By improving the efficiency of the FOCL operation on the basis of a transmitting and receiving optoelectronic module (ROM and TOM) optical ST optoelectronic SC with the introduction of the latest network technologies WDM and DWDM, we understand the procedures in which, given an optical network structure, the characteristics of information efficiency are determined with an acceptable minimum BER [19, 20].

The specified double ring FOCL structure in local data networks is considered. The object of the study – the structure FOCL is shown in figure 1.

In the scheme, the secondary ring is a backup and the service data necessary for controlling the transmission and monitoring the integrity of the network are transmitted through it.

In case of failure, when the primary ring is unable to transmit data (cable break, communication center failure, failures, failures, etc.), the secondary ring is activated, which supplements the primary ring, again forming a single logical ring [21, 22, 23].

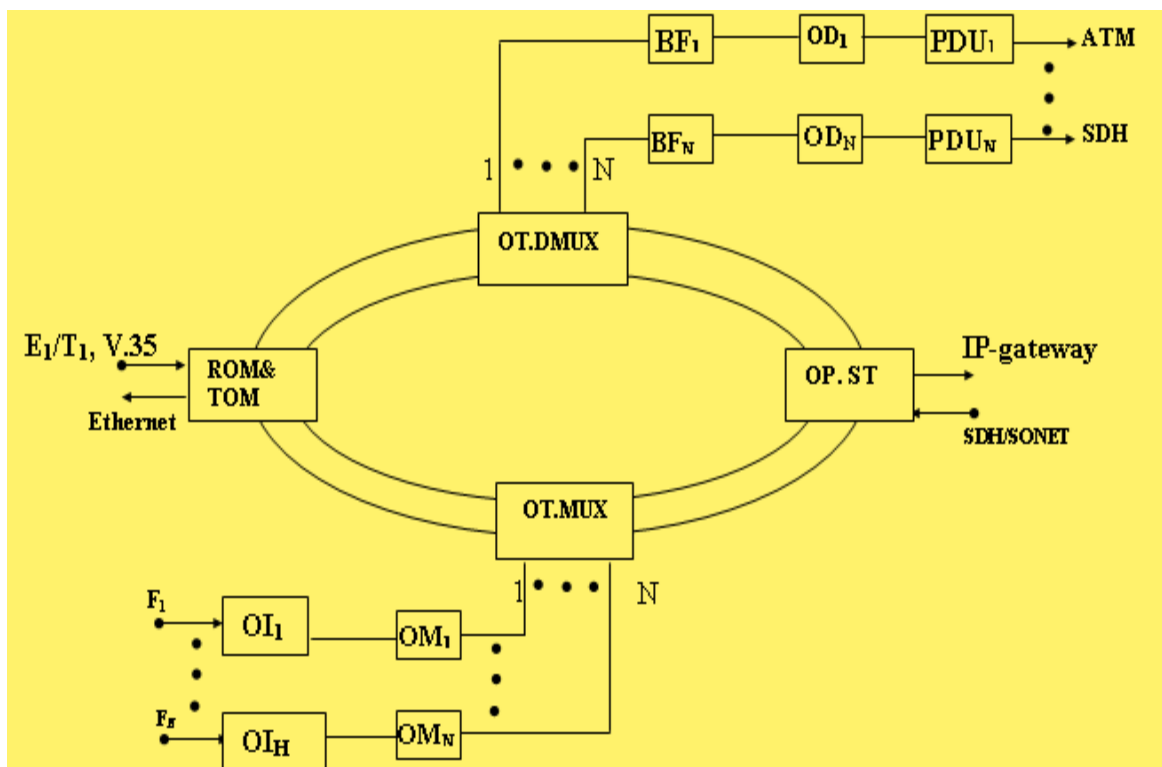

Fig. 1. FOCL double ring structure configuration

Considering the FOCL operation algorithms with a double ring structure based on TOM and ROM, their required capacities are made up of the main $C_{oc,max}$ and the reserve $C_{r,max}$ capacities at the maximum load of the system ρ_{max} [24, 25]:

$$C_{max}(\rho \leq \rho_{max}) = C_{os,max} + C_{r,max} \quad (2)$$

It was determined that the optical flows outgoing, terminal and transit traffic with a frequency $F_1 \div F_N$ from various sources (E1/T1, ATM (Asynchronous Transfer Mode), IP (Internet Protocol), SDH (Synchronous Digital Hierarchy) arrive at the inputs optical interfaces for processing and controlling the transmission optical signals [26].

SEZIONE 8.

SCIENZE MILITARI, SICUREZZA NAZIONALE E SICUREZZA DEL CONFINE DI STATO

These optical streams with a carrier wavelength $\lambda_1, \dots, \lambda_N$ are processed by the corresponding optical interface units Ol_1, \dots, Ol_N and then the carrier frequency bands are modulated with the help of optical modulators OM_1, \dots, OM_N .

Modulated optical carriers with a wavelength $\lambda_1, \dots, \lambda_N$ are multiplexed using optical terminal multiplexers (OT. MUX) based on the technologies spectral and dense spectral channel compression [6], which after amplification with an optical amplifier (OA) are fed to FOC with single-mode fibers, with mixed non-zero dispersion as recommended by ITU-T G.655 [10, 11, 27].

EVALUATION OF THE PERFORMANCE OF OPTICAL SIGNAL TRANSMISSION SYSTEMS

Considering the proposed algorithm for controlling the transmission of optical streams, the information efficiency of FOCLs operating in a ring topology with an allowable $C_{max.all.}$ is defined as follows [6, 28]:

$$E_{ie}(C_{max} \geq C_{max.all.}) = \frac{1}{N_k} \cdot \sum_{i=1}^{N_k} V_{i.b} \cdot \Delta \ell_{i.max}, \quad i = 1, 2, \dots, N_k \quad (3)$$

de V_{ib} – optical bit rate optical ST i -th optoelectronic SC in multiservice low- and high-speed ring SONET & SDH local networks, where the bandwidth $C_{max} = (2 \div 155)$ Mbps and $C_{max} \geq 155$ Mbps, respectively;

$\Delta \ell_{i.max}$ - the maximum length between the two i -th TOM and ROM, i.e., the length between the two i -th regeneration section of the FOCL;

N_k – the number of multiplexed optoelectronic CC ($16 \leq N_k \leq 64$).

Expression (3) characterizes the average information efficiency optical ST, which is a complex criterion for evaluating any FOCL structure with the introduction of spectral and dense spectral compaction CC, determining measures to improve the efficiency of the terminal facilities of modern fiber-optic networks.

Another way to improve the efficiency of transmission systems is to increase the FOCL energy potential using highly sensitive photodiodes (avalanche or p-i-n photodiodes), determined by the difference between the maximum possible transmit power level P_{tom} and the minimum acceptable level of receiving P_{rom} from optical signals for a given ROM sensitivity [29]:

$$E_{ep}(S_s \leq S_{s.all.}) = P_{tom} - P_{rom} \quad (4)$$

Based on the latter, the FOCL energy potentials, taking into account the sensitivity of ROM for various bit-rate transmissions depending on the length between its nodes, are determined by the following functional dependence:

$$E_{ep} = [\max(P_{tom}, L_{max}), \min(S_s, \alpha_{th}, P_{pa})] \quad , \quad (5)$$

where α_{th} – the threshold value of the attenuation of the length of the regeneration section, which is equal to $\alpha_{th} = E_{ep} \cdot L_{max}$, characterized by the maximum kilometric attenuation of the optical signal in the FOC; P_{pa} – maximum permissible attenuation FOCL and is the expression [2, 30]:

$$P_{max.pa} = P_{in} + (-S_s) \quad (6)$$

From the expression (4), (5) and (6) it follows that an important characteristic FOCL based on optical ST is the input power of the received optical signal – the ROM sensitivity in (A/Vt) and taking into account the current I_c at the output OpA is determined as follows:

$$S_s = I_c / P_{tom} \quad , \quad A / Vt$$

RESEARCH THE SENSITIVITY OF AN OPTICAL FOCL RECEIVER

It is obvious that the minimum value of the average optical power required to transmit signals with a permissible probability error P_{BER} is the sensitivity of the optical receiver FOCL.

The latter, taking into account the voltage of a single 1 and zero 0 signal (U_1, U_0) and the frequency of the signal n_f , is determined by the expression [5, 19]:

$$S(\lambda_i, P_{ou.0on}) = \frac{U_1 + U_0}{V_{i.b} \cdot n_f} \quad (7)$$

Suppose a photocurrent passes through the load R_H of an optical FOCL receiver, then the current sensitivity of the ROM for an avalanche photodiode $S(\lambda)$ with no multiplication M is determined as follows:

$$S(\lambda_i) = I_{\phi}(\lambda_i) \cdot (P_{i.ex} \cdot M)^{-1} \quad , \quad A/Vt \quad (8)$$

Based on the developed method for calculating the FOCL performance indicators taking into account the parameters non-linear effects of single-mode FOC in figure 2 shows the graphical dependence of the current sensitivity FOCL on the wavelength optical radiation for three specific values of the power of the input optical traffic P_{in} at a given bit rate of transmission of optical signals $V_b \geq 155$ Mbps.



SEZIONE 8.

SCIENZE MILITARI, SICUREZZA NAZIONALE E SICUREZZA DEL CONFINE DI STATO

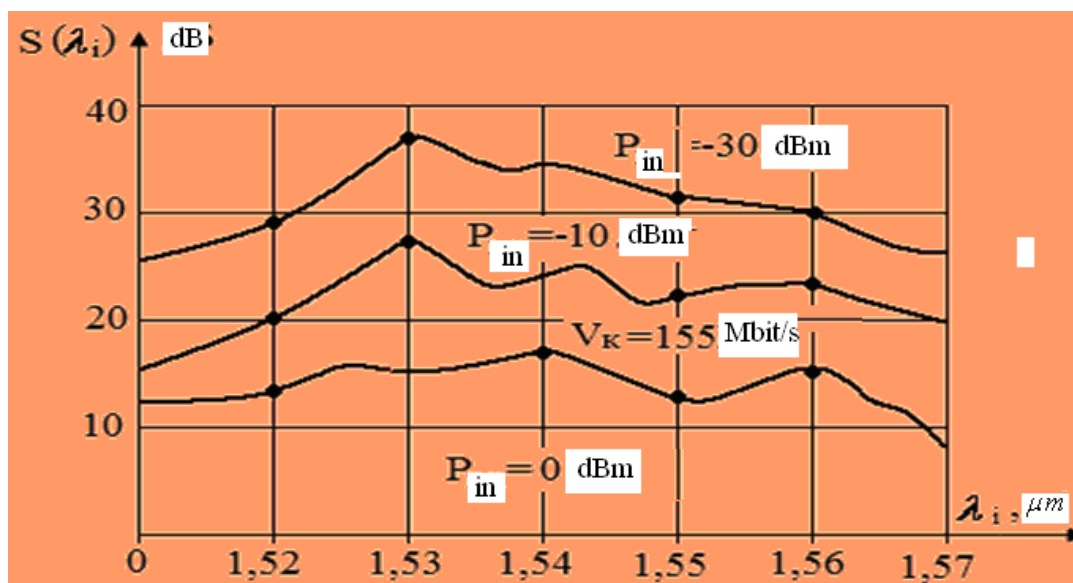

Fig. 2. **Graphic dependence of the current sensitivity of the ROM wavelength at a given bit rate optical signals**

Graphic analysis $S(\lambda) = F[P_{in}, \lambda, V_b]$ shows that with an increase in the transmission rate optical information for a given $P_{in} \geq -30$ dBm, FOCL current sensitivity decreases more slowly with $V_b \leq 622$ Mbps, $\lambda_i \leq 1,55 \mu m$.

This dependence characterizes the spectral characteristics FOCL based on optical WDM & DWDM technologies, i.e. dependence of the main quality indicators on the wavelength optical radiation. Its significant growth begins with the values $\lambda \geq 1,51 \mu m$

THE ALGORITHM OF THE WORK ROM AND DETERMINE THE BER RECEPTION OPTICAL SIGNALS

The ROM operation algorithm is that the FOCL receives optical streams from the FOC input, amplifies it with a preamplifier and demultiplexes. Then it separates into component optical streams with a carrier $\lambda_1, \dots, \lambda_N$ using band-pass filters (BF₁, ..., BF_N) to reduce transient noise, then to increase the noise immunity reception, they are detected using an optical detector (OD₁, ..., OD_N).

After some conversion, the optical signals are demodulated by a pulse detector unit (PDU₁, ..., PDU_N), which restores the original coding of digital pulse sequences [6, 18] fed to the input of the corresponding in ATM and SONET/SDH (Synchronous Optical Network / SDH) output .

At the same time, the sensitivity of the PROM optical ST, which is the average number of photons per bit and taking into account the operating algorithms OD

and PDU, with the permissible probability bit error P_{BER} reception is determined by the expression:

$$S_s(P_{BER} \leq P_{BER.all}) = (P_0 + P_1) \cdot (h\nu \cdot V_b)^{-1} \quad (9)$$

Expression (9) determined the minimum power of the input optical signal taking into account the power of a single 1 and zero 0 signal (P_1, P_0), at which $P_{BER} \leq P_{BER.ll}$ is provided. Depending on the algorithm of the optical demodulator (ODM), which characterizes the integral indicators FOCL noise immunity.

It has been established that the BER receiving optical signals with an increase in the bandwidth of the F ST optoelectronic CC will increase the clock frequency, which leads to an increase in the sensitivity to FOCL interference.

This interference may limit the reliability of the transmission and reception of optical signals. In this case, the most reasonable for making a decision is to know the average values of the voltage of the optical signal $u_{cp,max}$ and the threshold level Π_{cp} based on the voltage threshold of zero P_0 and the single signal P_i , respectively [20, 24].

For estimating the average BER of reception, the algorithm determining the optimal value of the parameters of the error rate η_0 and the limiting signal to noise ratio $\eta(t)$ at time t – at the input of the decision block optical ST with Gaussian distribution, which is as follows [6, 29]:

$$P_{BER}(\bar{I}_0 \leq u_{\bar{I}.max} \leq \bar{I}_1) = 0,5 \left[1 - \left(\sqrt{2\pi} \right)^{-1} \cdot \int_0^{\eta_0} \exp\left(-\frac{t^2}{2}\right) dt \right], \quad (10)$$

where η_0 – parameter error rate and taking into account the degree possible influence intersymbol interference δ_m optical terminal is determined as follows [6, 27]:

$$\eta_0 = 0,5 \left(1 - \frac{U_0}{U_1} \right) \cdot \delta_m \cdot (P_0 / P_1) \cdot [\eta(t)]^{0,5}, \quad 0 \leq \delta_m \leq 1, \quad (11)$$

where $\eta(t)$ – limiting signal-to-noise ratio at the input of the receiver of the optical terminal, which is expressed on the basis of total noise N_Σ as follows [7, 8, 19]:

$$\eta(t) = E_s / N_\Sigma, \quad N_\Sigma = (N_0 + N_{ni}) + \frac{(N_a - 1)}{\Delta F} \cdot P_i \quad (12)$$

where N_0 - the spectral density of the additive white Gaussian noise;

ΔF - bandwidth receiver; P_c – average signal strength;

N_a – is the number of active ST in FOCL; N_{ni} – the number of internal sources of interference;

E_s – optical signal energy; U_0, U_1 – voltage of zero and single signal, respectively.



SEZIONE 8.

SCIENZE MILITARI, SICUREZZA NAZIONALE E SICUREZZA DEL CONFINE DI STATO

To assess the reliability performance of the FOCL based on the obtained analytical expressions using this method, numerical calculations were determined for various input data using the MATLAB 8.5 system and its Signal Processing Communications packages and the following results were obtained:

$$\lambda = 1,31 \mu m, V_b \geq 2 Mbps, \Delta l_{max} = (50 \div 80) km, N_k = 2400 \text{ chanel and } P_{BER} \leq 10^{-9} \div 10^{-10}.$$

From the numerical calculations, it follows that the obtained satisfies the specified requirements $P_{BER} \leq P_{BER.all.}$ as recommended by ITU-T G.821 and G.828. which are shown below in table 1.

Table 1

Level of hierarchy	Indicators of the effectiveness of optical signal transmission systems					
	$\lambda, \mu m$	$V_b, Mbps$	$\Delta l_{max}, km$	P_{BER}	N_k (Chan)	$E_{ie}, \frac{Mbps}{s} \cdot km$
E ₁	1,3	2,048	50	$\leq 10^{-9}$	30	102,40
PDH	0,85	8,448	60	$\leq 10^{-9}$	120	506,88
T ₁	1,3	1,544	70	$\leq 10^{-9}$	20	108,08
SDH	1,28	155,520	80	$< 10^{-10}$	2430	12441,60
SONET	1,31	152,654	80	$< 10^{-10}$	2430	13267,40

After analyzing the data in the table, we can conclude that the problem of selecting information efficiency of the FOCL is an optimization problem depending on the attenuation of the FOC and the optical bit rate ST, determined from the condition $P_{BER} \leq P_{BER.all.} = 10^{-9}$ depending on the operation algorithm ODM with high sensitivity and less dark current as recommended by ITU-T G.821 [7, 12, 15].

CONCLUSIONS

Studies have shown that improving the efficiency of the FOCL on the basis of optical ST optoelectronic CC, is achieved by improving their energy potential and information efficiencies, thanks to the quality of the ROM and TOM.

The proposed criteria characterize the integral indicators of the functioning optical signal transmission systems based on spectral and dense spectral compaction with frequency separation CC and are objective and sufficiently simple to evaluate the quantitative and qualitative characteristics FOCL using optical ST.

REFERENCES:

[1] Ibrahimov, B. G., Ismaylova, S. R., Hasanov, A. H., & Isayev, Y. S. (2023, June). Research and analysis criterion quality of service and experience multifractal traffic using fuzzy logic. In Recent Developments and the New Directions of Research, Foundations, and Applications: Selected Papers of the 8th World Conference on Soft Computing, February 03–05, 2022, Baku, Azerbaijan, Vol. I(pp. 387-397). Cham: Springer Nature Switzerland.

- [2] Ibrahimov, B. G., Namazov, M. B., Humbatov, R. T., & Guliyev, M. N. (2022, August). Investigation and analysis of immunity characteristics receiving discrete messages. In Proceedings of the 8-th International Conference on Control and Optimization with Industrial Applications (Vol. 2, pp. 237-239).
- [3] Kikuchi K., Miyazaki T., Nakazawa M. High Spectral Density Optical Communication Technologies. Optical and Fiber Communications Reports. Springer, 2010. – 346 P.
- [4] Ibrahimov B. G. (2023) Research quality of functioning of the efficiency optical telecommunication systems using spectral technologies// In Проблеми інформатизації, Т.1. p.29-30.
- [5] Ибрагимов, Б. Г. О., Гасанов, А. Г. О., Алиева, А. А. К., & Исаев, А. М. О. (2019). Исследование показателя качества функционирования мультисервисных телекоммуникационных сетей на базе архитектурной концепции будущих сетей. Надежность и качество сложных систем, (1 (25)), 88-95.
- [6] Ibrahimov, B., Hasanov, A., & Hashimov, E. (2024). Research and analysis of efficiency indicators of critical infrastructures in the communication system. Advanced Information Systems, 8(2), 58-64.
- [7] Ibrahimov, B. G., Orujov, A. O., Hasanov, A. H., & Tahirova, K. M. (2021). Research and analysis efficiency fiber optical communication lines using quantum technology. T-Comm-Телекоммуникации и Транспорт, 15(10), 50-54.
- [8] Bayram Ibrahimov, Asmer Nabieva. Research Interference Immunity Multiservice Corporate Communication Networks//Proceedings of the 9-th International Conference on Control and Optimization with Industrial Applications (COIA-24). IEEE, (27 - 29 август). Istanbul, Turkiye. 2024. pp. 360 – 363.
- [9] Bayram G. Ibrahimov, Almaz Aliyev, Ulvi R. Rafizade. Research on the Effectiveness of Wireless Networks Cellular Communications Based on Digital Technologies// Information Technologies and Their Applications Second International Conference, ITTA 2024. Proceedings, Part I. Baku, Azerbaijan, April 23–25, 2024. pp. 55 - 66. The Editors and The Authors, under exclusive license to Springer Nature Switzerland AG 2025.
- [10] Ibrahimov, B., Islamov, I. (2025). Research and Analysis of the Efficiency of Fiber-Optic Communication Lines Based on DWDM Systems. In: Durakbasa, N.M., Gülen, K.G. (eds) Sustainable Green Conversion. ISPR 2024. Lecture Notes in Mechanical Engineering. Springer, Cham (03 may 2025). pp. 81-91.
- [11] Ibrahimov, B., Nabieva, A., & Hamidova, A. (2025). Research spectral efficiency of new modulation formats in fiber-optic networks. *Reliability: Theory & Applications*, 20(SI 7 (83)), 81- 89.
- [12] Orujova, M. Y., Ismaylova, S. R., & Ibrahimov, B. G. (2025, March). Research Information Security System in Event-Based Security and Reliability Management. In *2025 Systems of Signals Generating and Processing in the Field of on Board Communications* (pp. 1- 4). IEEE.
- [13] Ибрагимов, Б. Г., & Исмаилова, С. Р. (2014). Исследование и анализ эффективности мультисервисных сетей связи при использовании архитектурной концепции NGN. T-Comm-Телекоммуникации и Транспорт, 8(8), 47-50.
- [14] Ibrahimov, B. G., & Ismaylov, Z. A. (2025, March). Qualitie of Communication Fiber-Optic Transmission Systems Using Wave Multiplexing Technology. In *2025 Systems of Signals Generating and Processing in the Field of on Board Communications* (pp. 1- 4). IEEE.
- [15] Ибрагимов Б. Г., Мамедов И. А., Садыгов У. К.. Исследование качества функционирования телекомму-никационных систем в критических информационных инфраструктурах//Вестник компьютерных и информа-ционных технологий. 2025. Т. 22, № 2. С. 55 – 62.

SEZIONE 8.

SCIENZE MILITARI, SICUREZZA NAZIONALE E SICUREZZA DEL CONFINE DI STATO

- [16] Ibrahimov, B. G., & Javadova, M. M. (2025). The problem synthesis algorithms for predicting congestions in wireless communication network. pp.100-101.
- [17] Ibrahimov, B. G., & Hashimov, E. G. (2025). Special purpose machine learning and data mining methods. pp. 90.
- [18] Ibrahimov, B. G., & Ismaylov, Z. A. (2025, May). Research on the Efficiency of Telecommunication Networks Using Wireless Communication Technology. In *2025 Wave Electronics and its Application in Information and Telecommunication Systems (WECONF)* (pp. 1-5). IEEE.
- [19] Ibrahimov B. Research and analysis machine learning methods in network security in telecommunication system. *Int Rob Auto J.* 2025;11(2):40–42.
- [20] Ibrahimov, B. G., Yusifov, C. A., & Binnetov, M. F. (2025, June). Research Methods of Assessing the Efficiency Information Protection Systems in Multiservice Communication Networks. In *2025 Systems of Signal Synchronization, Generating and Processing in Telecommunications (SYNCHROINFO)* (pp. 1-4). IEEE.
- [21] [Ибрагимов, Б. Г., Гумбатов, Р. Т., Ибрагимов, Р. Ф., & Исаев, А. М. (2019). Анализ показателей производительности мультисервисных телекоммуникационных сетей будущего поколения с использованием технологий программно-конфигурируемых сетей. Вестник компьютерных и информационных технологий, (4), 39-44.
- [22] Ибрагимов, Б. Г. О., & Гусейнов, Ф. И. О. (2015). Исследование и анализ эффективности передачи мультимедийного трафика в сети NGN/IMS. *T-Comm-Телекоммуникации и Транспорт*, 9(12), 27-31.
- [23] Ibrahimov, B. G., & Alieva, A. A. (2019, August). An approach to analysis of useful quality service indicator and traffic service with fuzzy logic. In *International Conference on Theory and Application of Soft Computing, Computing with Words and Perceptions* (pp. 495-502). Cham: Springer International Publishing.
- [24] Ибрагимов, Б. Г. (2018). Анализ мультисервисных телекоммуникационных сетей связи будущего поколения на базе архитектурной концепции SDN&NFV и IMS. *Ученые-записки*, (3), 34
- [25] Listvin V.N., Treshchikov V.N. DWDM systems. Moscow.: Technosphere, 2015. - 256s.
- [26] Ibrahimov B, Sadigov U. Research information protection system of important objects critical information infrastructure. *Int Rob Auto J.* 2025;11(2):44–48.
- [27] Ибрагимов, Б. Г. (2018). Анализ мультисервисных телекоммуникационных сетей связи будущего поколения на базе архитектурной концепции SDN&NFV и IMS. *Ученые-записки*, (3), 34.
- [28] Ибрагимов, Б. Г. О., Биннатов, М. Ф. О., & Исаев, Я. С. О. (2018). Исследование пропускной способности сетей NGN/IMS при установлении мультимедийной сессии. *T-Comm-Телекоммуникации и Транспорт*, 12(3), 9-12.
- [29] Ибрагимов, Б. Г., & Мамедов, И. М. (2012). Исследование эффективности оптических транспортных сетей с использованием передающего и приемного оптоэлектронного модуля.
- [30] Ibrahimov, B. G., & Mammadov, S. M. (2010). The study and estimation of the performance attributes of terminal hardware for a link in a multiservice communication network. *Automatic Control and Computer Sciences*, 44(6), 359-363.